



TRUMPF



TruMark

The individual
solution for
your industry



3D Black Marking with TruMicro Mark 1020 on an additively manufactured titanium hearing instrument

The diversity of marking

Start here to find your ideal marking laser. No matter which marking laser requirements are especially important to you: Discover how TRUMPF can support you in selecting your hardware and software, and advise you on your individual process. Together with TRUMPF, you will be prepared for the production processes of the future – through expert knowledge of Industry 4.0, Smart Factory and through providing custom-made, top-class services.

What really counts is quality, performance and safety.

**TruMark:
This is what you can expect
4–5**

The right solutions for your sector.

**What type of user
are you?
6–9**

Joint process development in the TRUMPF Laser Application Centers.

**Together, we will find the
right marking laser for you
10–13**

Discover your perfect marking laser here.

**An overview of the
TruMark marking lasers
14–31**

Your software solution: standardized or tailor-made.

**Everything under control
with TruTops Mark
32–37**

Services and support to get your competitive edge.

**TruServices.
Your Partner in Performance
38–43**

All the technical information you need at a glance.

**Technical data
44–49**

TruMark: This is what you can expect

Your production process depends on a marking laser – TRUMPF understands. With our international sales team, we are always somewhere close-by. As a full-service provider, we offer marking systems with various options, software solutions such as image processing, and a selection of lenses. Trust in the power of the latest TruMark generation.

Quality

TruMark lasers provide components with high-quality and durable markings with maximum precision. The parameter library enables quick optimization of the marking process, while VisionLine enables distance measurement, workpiece recognition, and the reading and evaluation of codes, fonts, and numbers for traceability and quality assurance.



**No compromises
on quality**

Performance

Lasers with different power levels and pulse duration ensure that the right laser is available for every requirement. Short processing times are ensured thanks to fast laser availability and a highly dynamic scanner.



**High speed for your
processes**

Safety

With Performance Level e, system safety remains a top priority during integration. With Plug & Produce, nothing can go wrong, even during component exchange. Additional components such as mechanical shutters provide further protection.



**Play it safe with TruMark
marking lasers**

Energy efficiency

The stand-by mode for TRUMPF marking lasers reduces power input by almost 50%. The laser system is immediately ready for use again as soon as a new marking job is received.



**Energy-efficient system
solutions from a single source**



TruServices

We offer best-in-class remote and on-site service with a remote resolution rate of over 75%. Our global service network has trained specialists and ensures up to 10 years availability of spare parts and global delivery. In addition, various international training centers with a wide range of programs are available.

All-round support from our TruServices

Laser Application Center

Experience laser processing live in our showrooms all over the globe. Our application specialists mark and optimize your component samples directly on site. During this time, you can see the machines in operation and receive a personal consultation.

Our showrooms for laser technology

Qualification

We are also happy to support you through our IQ/OQ services during the qualification process to meet the certification requirements in your industry. Among other things, our focus is on medical technology and the aerospace industry.

Safely install and qualify laser systems



View our comprehensive overview of all TruMark marking lasers:
www.trumpf.com/s/markinglasers



What type of user are you?



**“In the medical industry,
every part must be traceable.
TruMark is the marking solution
that has my absolute trust.”**
Caroline T., Quality Assurance Officer



Find out more about
our medical technology
solutions:
[www.trumpf.com/s/
medical-technology](http://www.trumpf.com/s/medical-technology)



Medical Engineering

Process reliability first

TruMark lasers inscribe medical devices and instruments, as well as implants, with absolute precision. With their ability to focus very precisely, they can create even the finest markings on sensitive surfaces and meet all the criteria for perfect UDI (unique device identification) markings. Short pulse durations in the range of picoseconds or femtoseconds ensure the highest degree of contrast and maximum corrosion resistance – with minimal heat penetration and without residues on the surface. Black marking negates the need for downstream passivation processes, and therefore decreases the overall process time.



Traceable due to durable marking: With its extreme pulse peak power, the TruMicro Mark generates deep black UDI codes with enhanced corrosion resistance for traceability.



UDI-code perfect and compliant: Laser-marked endoscope made of surgical steel.



TruMark lasers mark different materials, including plastics, such as this positioning aid for implants (SAMAPLAST AG). The appropriate wavelength is available for each material.

What is especially important to you in a marking laser? Ease of integration into your production line? Marking speed? Efficiency? High availability? Best marking quality? No matter what your priorities are – you'll find your perfect TruMark marking laser here.



“In the electromechanical industry, I need high marking quality without system failures, something I can use quickly and flexibly. TruMark is just the thing!”

Alexander S., Purchaser



Further information can be found here:
www.trumpf.com/s/kpayxm



Electronics

Highest performance, maximum reliability

Housings, switches, power supply units, circuit boards: With TruMark marking lasers, you can mark and structure many different electromechanical industry components in high quantities – contactless, durable, and free of wear.



UV marking lasers can mark even flame-retardant materials in high quality using ultraviolet wavelengths.



Even highly reflective materials such as copper can be easily marked using TruMark lasers.



Benefit from short cycle times thanks to the scalable laser power and short reaction times.

What type of user are you?



**“In the automotive industry,
I need an overall system that
is efficient. The TruMark is the
ideal marking laser for that.”**

Joerg M., Process and System Planner



Find out more about
our mobility solutions:
[www.trumpf.com/s/
rftzd4](http://www.trumpf.com/s/rftzd4)



Mobility

Maximum system efficiency, simple integration

During vehicle production, numerous components such as efficient batteries are used, each of which must carry specific designations and traceability information. Individual TruMark laser systems offer companies from the mobility industry numerous application options, for example for permanent marking, cleaning, and functionalization of surfaces such as adhesive bonding preparation. The modular design of the TruMark laser systems with their many options makes them versatile, easy to expand, and compact.



VisionLine image processing and integrated autofocus provide traceability.



TruMark lasers are multifunctional tools for the mobility industry.



By foam marking: Barcodes and marking rear car lights with free text.



“With household appliances, all the marking possibilities are needed, and for this I need exactly one solution: TruMark.”
Marc E., Technology Officer

White goods and household items

Highest marking quality, utmost flexibility

Household appliances have many visible parts. Here, exceptionally high-grade, durable, and haptically high-quality marking is essential. The applications within the sector are diverse, calling for flexible solutions with regard to focal lengths, marking field sizes, or wavelengths.



With TruMark marking lasers, you can mark household appliances highly economically and to an exceptional standard.

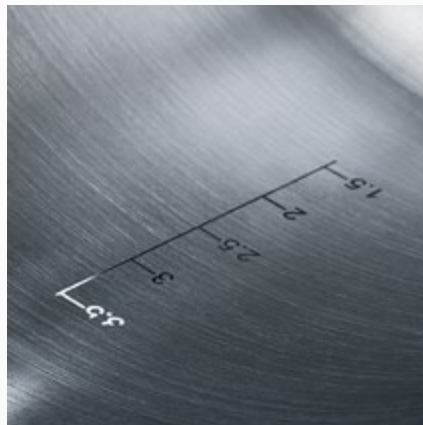

The TruMark lasers even mark more complex forms with precision.



You can work cleanly and with a high degree of precision, and even easily remove paint from sheets just using a marking laser.

Together, we will find the right marking laser for you

We are by your side right from the start, no matter whether you have basic application questions or detailed optimization requirements. In our Laser Application Centers (LAC) we are ready and waiting to assist you – no matter when, no matter where. This is because we want you to find the right partner in the right place who always has the optimum technologies for your needs.

✓ Determining factors

Specify the determining factors for your marking task, such as desired process duration, parts handling or production environment.

✓ Marking content

Supply us with sample components and the desired marking content (logo, text, data matrix code, etc.).

✓ Marking procedure

We will identify the ideal marking procedure for you, with a perfectly balanced combination of marking result, laser beam source and workstation. We develop optimum process parameters for you, tailored to your criteria.

✓ Installation

If you wish, we can accompany and support you further with installation, training, maintenance, telephone support, and other services.



“We have always been able to rely on the service from TRUMPF throughout our long years of collaboration. I appreciate the fact that I can always count on the highest process reliability in my marking tasks.”

Jürgen Diesenberger, Production Director for Instruments and Sterile Technology, Karl Leibinger Medizintechnik GmbH & Co. KG



“The trend in laser marking is moving in the direction of industry-specific solutions, such as in software and increased machine intelligence. It is important to us that marking lasers always meet the requirements of an industrial environment, and that their installation, commissioning, and operation is as simple as possible. Additionally, we offer our customers sustained collaboration they can trust.”

Holger Breitenborn, product manager for marking lasers and systems

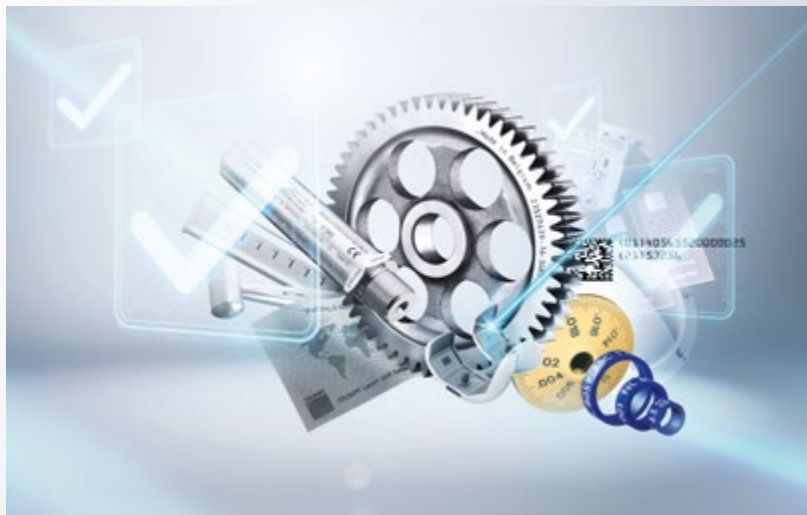

“We benefit significantly from the experience TRUMPF provides. The high dependability of their systems and the international availability of spare parts ensure our production success.”

Ricus Müller, Senior Technical Expert for Manufacturing Technology / Process Development, Continental Temic microelectronic GmbH



Find out more about how we can help you at our Laser Application Centers here: www.trumpf.com/s/process-optimization



Your laser, your choice: With our product finder!

You can also easily find your perfect TruMark using the online configurator. Please answer a few questions concerning your application, and we will show you which laser is best for you!



MATERIAL

RESTART →

1 2 3 4 5 RESULT →

Which material do you want to mark?

Select the option that meets the majority of your requirements.

<div style="border: 1px solid #ccc; padding: 5px;"> <p>Metal</p>  <ul style="list-style-type: none"> Mild steel, stainless steel, titanium, aluminum, non-ferrous metal, various alloys and more Flexible and fast marking on metal without the use of chemicals </div>	<div style="border: 1px solid #ccc; padding: 5px;"> <p>Plastic</p>  <ul style="list-style-type: none"> Wide selection of markable polymers Perfect adaptation of wavelength and material Use of the optimal wavelength for the respective material Marking speed can be increased with additives </div>
<div style="border: 1px solid #ccc; padding: 5px;"> <p>Other</p>  <ul style="list-style-type: none"> Glass, ceramic, textiles and more Flexible material selection through the optimal use of different wavelengths </div>	

NEXT STEP





PROCESS

RESTART →

1 2 3 4 5 RESULT →

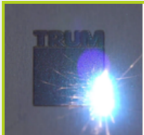
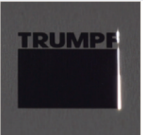
Which process do you want to use most often?

<div style="border: 1px solid #ccc; padding: 5px;"> <p>Engraving</p>  <ul style="list-style-type: none"> Material removal through melting and evaporation Various types of engraving such as black engraving, white engraving and deep engraving are possible Combination of black and white engraving for a particularly high contrast for data matrix codes </div>	<div style="border: 1px solid #ccc; padding: 5px;"> <p>Annealing</p>  <ul style="list-style-type: none"> By heating the material, oxide film is generated on the workpiece surface and the color changes Maintenance of the surface structure Especially used for ferrous metals and titanium </div>
<div style="border: 1px solid #ccc; padding: 5px;"> <p>Cleaning / Structuring</p>  <ul style="list-style-type: none"> The laser removes unwanted layers on the component, either very precisely and localized or over a large area Surface contamination such as oils, grease, oxides and residues can be removed at high speed </div>	<div style="border: 1px solid #ccc; padding: 5px;"> <p>Black marking</p>  <ul style="list-style-type: none"> Cold material removal by black marking enables corrosion-resistant markings Excellent legibility of the marking regardless of the viewing angle High-precision markings on a wide range of materials are possible </div>

BACK

NEXT STEP



One-box laser

Outstanding and compact cost-effectiveness

01

Compact design

without supply unit

05

Simple integration

with the innovative one-box concept

02

Versatile

and thus suitable for a wide range of marking tasks



03

Low investment costs

thanks to the excellent price-performance ratio

04

Minimal maintenance

through practical design

01

Compact design

without supply unit

TruMark 1110 and TruMark 5010 combine medium power with brilliant beam quality. Space-saving, air-cooled, and equipped with the most important interfaces, the marking lasers can be easily integrated into the TruMark Station 3000. The one-box lasers are a true all-in-one solution. Their housing combines fiber laser, scanner, control, and internal focal position control. There is no need for a separate supply unit.

02

Versatile

and thus suitable for a wide range of marking tasks

Do not underestimate the two lasers just because they are small! With the one-box lasers, you can mark metals, plastics, and organic materials – with brilliant beam quality. Material processing can also be carried out efficiently and reliably at higher pulse frequencies.



Day-and-night design for the automotive industry: The marking laser partially removes top layers of multi-layer plastics. The difference in color creates the design effect.

03

Low investment costs

thanks to the excellent price-performance ratio

The one-box lasers enable cost-effective laser processing, even for small to medium quantities. They are therefore also well-suited for anyone who wants to incorporate laser marking into their production without having to compromise on quality.

04

Minimal maintenance

through practical design

In dirty environments, you only need to change the filter mats and clean the protective glass.



Mark Data Matrix Codes in your tools with black engraving for easy management.

05

Simple integration

with the innovative one-box concept

The one-box lasers do not require a supply unit and are equipped with many interfaces. This makes it easy for you to integrate them into production processes. Clever and powerful air cooling also prevents the component from overheating.



The many available interfaces for the one-box lasers make integration into your production line easier.



Everything else you want to know about the one-box lasers: www.trumpf.com/s/one-box-laser



TruMark Series 3000

The tried-and-tested top solution for a wide variety of materials and applications.

01

Excellent results

thanks to a perfectly tuned performance package

05

Perfect for all components

thanks to its internal focus position control unit

02

Flexible material selection

using green and UV wavelengths



03

High availability

thanks to ingenious design

04

Integration made easy

thanks to compact size and modular design

01

Excellent results

thanks to a perfectly tuned performance package

Enjoy top-quality markings. The TruMark Series 3000 is an attractive proposition with its bundle of technical top ratings: reliable pulse-to-pulse stability, brilliant beam quality, and high pulse energies.

02

Flexible material selection

using green and UV wavelengths

The lasers of the TruMark Series 3000 are available in green and UV wavelengths. These wavelengths enable you primarily to label and process polymers (also with flame retardants), ceramics, and glass. In addition, particularly fine and precise marking is possible. This means that you always achieve the optimum performance and quality for your application.



UV-marked speech processor with antenna.

03

High availability

thanks to ingenious design

The laser represents reliable performance even under difficult conditions. To further improve availability and to make maintenance quick and easy, the electrical components are separated from the optical ones.



Laser-marked electrical components: Information applied to the tiniest area facilitates the secure identification of the product at all times.

“The decisive factor for our team when purchasing the TruMark 3330 was the fact that it would be easy to integrate into our plant concept.”



Alexander S., Purchaser

04

Integration made easy

thanks to compact size and modular design

The modular design and compact dimensions of the processing unit of the TruMark Series 3000 make it especially easy for you to integrate the laser into your production system. Additionally, the removable hybrid cable and the numerous available interfaces ensure that start-up is convenient.

05

Perfect for all components

thanks to its internal focus position control unit

Does your workpiece include different heights? No problem! The TruMark Series 3000 possesses variable focal positioning adjustment, which allows you to process at different levels. In this way, you can continue production at different processing levels more quickly and with high process reliability.



Top-class markings on a diverse range of materials: Here a color change onto a flame-retardant plastic via the UV laser.



Find out everything else you would like to know about the TruMark Series 3000:
www.trumpf.com/s/trumark-series-3000



TruMark Series 5000

Our compact marking lasers for deep engraving, annealing marking, microstructuring, and surface treatment.

01

Save time

thanks to the high processing speed

05

Consistent performance

across the entire frequency range

02

Flexible with regard to material

thanks to adjustable pulse duration

03

Work in safety

with fiber protection duct and shutter

04

Easy to integrate

thanks to logical modular design



01

Save time

thanks to the high processing speed

The special thing about the TruMark Series 5000 is that it has high pulse frequencies – a key factor for high processing speeds. With its software-controlled focus position adaptation, you can mark components at different processing levels in one operation, without mechanically moving them.



In addition to laser marking, functional surface structures can also be specifically modified, thereby influencing the tribological characteristics.

02

Flexible with regard to material

thanks to adjustable pulse duration

Application-specific setting of the pulse duration while maintaining constant peak intensity and high pulse frequency means that you no longer have to choose between quality and productivity for your marking processes. After all, with reduced pulse duration, you also get high-quality marking results even with short cycle times – for a wide variety of materials.

03

Work in safety

with fiber protection duct and shutter

In addition to an especially robust fiber protection hose, the TruMark Series 5000 also possesses additional features such as a mechanical shutter and fiber plug monitoring between laser and processing unit. This means that operators can work safely even if the workstation is open.

“With its high performance and simple integration, the TruMark Series 5000 fits perfectly into my production line.”



Joerg M., Process and System Planner

04

Easy to integrate

thanks to logical modular design

The scanner optics, the processing unit, and the supply unit are coupled via connectors, so that it is very simple to build the laser into your production system or your plant. Numerous interfaces make integration into your production area even easier.

05

Consistent performance

across the entire frequency range

With TruMark Series 5000, you can be sure that your performance remains consistent across all frequency ranges – and thanks to its different power classes, it satisfies every requirement in terms of performance.

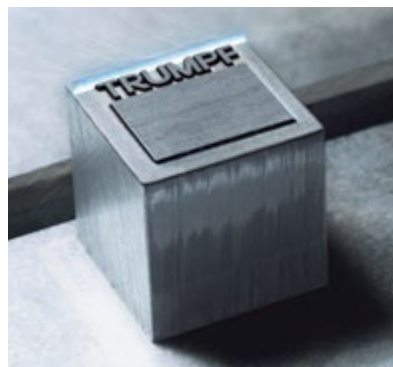

Deep engraving with high volume removal – no problem with the high performance of the TruMark Series 5000, even with short cycle times.



Find out more about the TruMark Series 5000 at:
www.trumpf.com/s/trumark-series-5000



TruMark 6030

A whole new dimension in marking.

01

High-quality markings

on complex 3D surfaces

05

Unlimited number of switching cycles

due to a design specifically for highly automated applications

02

Highly productive laser

with fast marking activation

03

Innovative safety concept and interface design

Performance Level e for unlimited switching cycles

04

Perfect machining results

due to integrated control



01

High-quality markings

on complex 3D surfaces

The TruMark 6030 enables 3D markings, even on complex components. Users can easily create geometries and marking content using the 3D CAD software. The new optical Z axis allows Z travel ranges of up to 100 mm. This eliminates additional costs for a mechanical axis to move the laser head.



3D plastic markings are in high demand in medical technology: test joint for hip implant (left); positioning aid for implant (right). Image source: SAMAPLAST AG

02

Highly productive laser

with fast marking activation

The TruMark 6030 reduces processing time with its high-capacity mid-range output and pulse energy at the workpiece. Outstanding beam quality and high irradiance ensure clean ablation and high-contrast markings. After closing the safety circuit, the laser is available within 50 ms. Integrating the output signal into the laser safety status not only provides additional freedom during integration – it can also further reduce processing time.

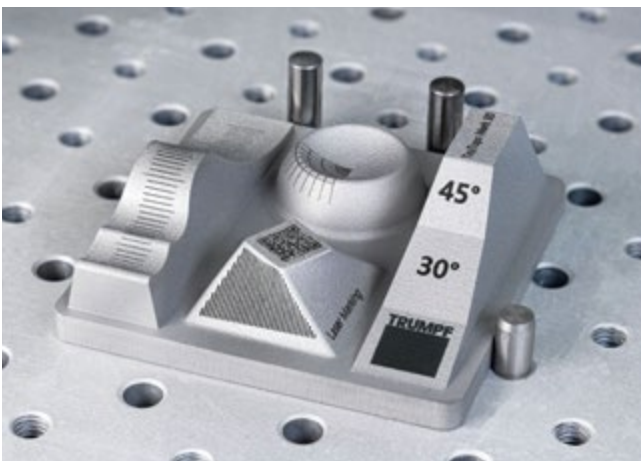

03

Innovative safety concept and interface design

Performance Level e for unlimited switching cycles

A self-monitoring safety concept ensures that there is no risk for the operator at any time or in any situation. Furthermore, it is also possible to integrate the laser into the production environment using OSSD-capable components (Output Signal Switching Device). Depending on how your system is designed, it is also possible to have unlimited switching cycles, meaning that laser maintenance for safety reasons does not have to be performed after a certain number of switching cycles.

04

Perfect machining results

due to integrated control

The TruMark 6030's closed-loop control ensures perfect machining results over the entire service life. Different frequency ranges, temperature changes or reduced pump output do not influence the laser output.

By using an external modulator, the laser power can be linear-scaled – parameters such as pulse duration or pulse stability are not affected. In addition, each individual laser pulse can be adapted exactly, which prevents crosstalk between the pulses. Softening and run-in behavior at the beginning of vectors are avoided. Strikingly sharp bitmap marks can be realized.

05

Unlimited number of switching cycles

due to a design specifically for highly automated applications

The optical and electronic design and manufacturing technologies used in the TruMark 6030 make it a robust, high-capacity, industrial marking system. The laser head comes standard with the capability of working in ambient temperatures of up to 40°C and, with a rating of IP64, is protected from the manufacturing environment. The unlimited number of switching cycles eliminates the need for certain safety maintenance measures and the associated planned downtime and costs. The laser can simply continue marking and producing components.



More details about the next dimension of marking:
www.trumpf.com/s/trumark-6030



TruMark 7050

More power, more speed, more flexibility, and more application possibilities.

01

Highest performance

thanks to 200 W average output and 10 kW or 50 kW peak power depending on the fiber

06

Maximum stability

thanks to the fast internal performance measurement system

02

Short process times

thanks to high average power and high pulse repetition frequency

03

Robust and reliable

thanks to modern production technologies

04

Excellent results

using the M-fiber or Z-fiber variant

05

Simple integration

in any production line



01

Highest performance

thanks to 200 W average output and 10 kW or 50 kW peak power depending on the fiber

The laser source of the TruMark 7050 has an average power of 200 W and a peak power of 10 kW with the Z fiber and 50 kW with the M fiber. This allows you to achieve the highest processing speeds and short cycle times. The device offers a new level of performance in labeling and thus opens up a wealth of new application possibilities.

02

Short process times

thanks to high average power and high pulse repetition frequency

The laser system achieves the optimal combination of high power, high pulse repetition frequency, and adjustable pulse duration to meet the highest productivity requirements.

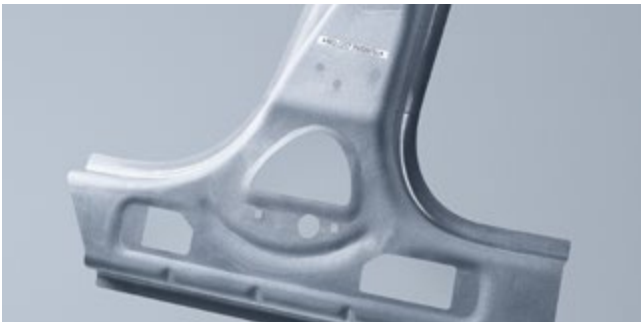

With TruMark 7050, you can create high-quality deep engravings, such as for the vehicle identification number (VIN) in the automotive industry.

03

Robust and reliable

thanks to modern production technologies

Modern production technologies and high-performance optical components make the laser a high-end industrial device.

04

Excellent results

using the M-fiber or Z-fiber variant

Depending on the fiber variant of the TruMark 7050, different beam diameters and peak energies are available, which enable both fine processing and cleaning at the highest speeds.



E-mobility applications require the connection of the same and different materials (e.g. copper with stainless steel or brass). With TruMark 7050, this is also possible with very thin materials and very little heat influence.

05

Simple integration

in any production line

TruMark 7050 was designed as a multifunction tool and is a turnkey solution that can be easily operated and quickly integrated into any production line due to the many interfaces, a detachable connection cable, and 19" plug-in units.

06

Maximum stability

thanks to the fast, internal performance measurement system

Consistent laser power is crucial for stable marking and processing quality, which is checked thanks to the fast internal power measurement system.

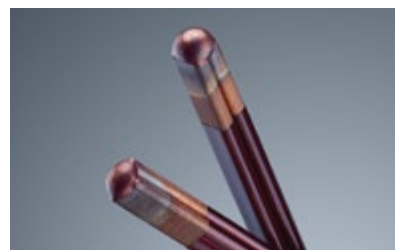

The TruMark 7050 can be used for hairpin stripping in electric motors, i.e. the removal of the electrically insulating plastic sheathing of copper cables as preparation for welding.



Everything else you want to know about the TruMark 7050: www.trumpf.com/s/trumark-7050



TruMicro Mark Series

Higher precision, more control, and more versatile applications.



01

Black marking

With extreme peak pulse power and ultrashort pulses

06

Efficient microprocessing^[2]

with high average power

02

The complete solution for marking applications

Covers a wide range of marking and microprocessing

05

Flexible pulse duration^[2]

Enables a wide range of applications

03

Specialist in medical technology

thanks to corrosion-resistant and machine-readable markings

04

Unlimited black marking^[1]

on complex three-dimensional shapes



01

Black marking

with extreme peak pulse power and ultrashort pulses

Create deep black, corrosion-resistant markings with extreme peak pulse power and ultrashort laser pulses in the femto- and picosecond ranges. In addition, the lasers of the TruMicro Mark Series impress with their high beam quality and thus ensure absolute precision.

02

The complete solution for marking applications

covers a wide range of marking and microprocessing

The multifunction tools cover a wide range of marking and microprocessing, e.g. UDI-compliant product identification in plain text with bar code or Data Matrix Code for traceability, or structuring, cutting, and drilling. The TruMicro Mark Series is available as an OEM version as well as a fully integrated and turnkey system in a TruMark Station.

03

Specialist in medical technology

thanks to corrosion-resistant and machine-readable markings

With the TruMicro Mark Series, you can mark implants and surgical instruments in a corrosion-resistant way. Even medical plastics that are difficult to write on, such as UHMWPE, can be marked thanks to our UKP technology. We are also happy to support you with our IQ/OQ services during the qualification process to meet the certification requirements in your industry.



The traceability of medical products, here using the example of a pacemaker, is extremely important, which makes machine-readable labeling crucial as well.

04

Unlimited black marking^[1]

on complex three-dimensional shapes

With the TruMicro Mark 1020, you can achieve an excellent processing result across the entire 2D and 3D marking scope. The laser's dynamic optical Z axis in combination with scanner optics adjusts the focus in three dimensions. TruMicro Mark 1020 can even use unlimited black marking, which allows you to place deep black and corrosion-resistant markings on complex three-dimensional shapes and in free form.

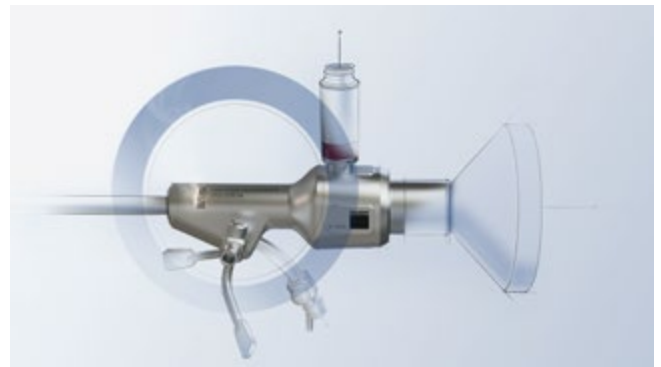

The TruMicro Mark 1020 uses unlimited black marking to mark three-dimensional objects such as this endoscope in free form.

05

Flexible pulse duration^[2]

enables a wide range of applications

With the TruMicro Mark 2030, pulse durations can be set flexibly, enabling a wide range of applications, high-grade engravings, or extremely delicate drilling and cutting.

06

Efficient microprocessing^[2]

with high average power

High average power, small focal diameter, telecentric lenses – with the special features of the TruMicro Mark 2030, you are ideally set up for precise and efficient microprocessing.

^[1] Special features of TruMicro Mark 1020.

^[2] Special features of TruMicro Mark 2030.



Everything else you want to know about the TruMicro Mark 1020 and 2030:
www.trumpf.com/s/trumicro-mark



TruMark Station 3000

The compact marking cube for small and medium-sized batches: simple and user-friendly.

01

Just get started

with intuitive operability

05

Mark safely

with a motorized laser protection door and laser safety class 1



04

Perfectly equipped

for any application or batch size

02

Work comfortably

because of our focus on ergonomics

03

Compact desktop application

with the TruMark one-box lasers and the TruMark 6030

01

Just get started

with intuitive operability

The TruMark Station 3000 is perfectly suited to customers with small and medium batch sizes. The spectrum of applications encompasses the removal, structuring and targeted coloring of surfaces. The simple, safe but industrially robust marking station is straightforward and comfortable to operate.



Laser-marked headrest: Make your customers happy with individually-designed single parts.

02

Work comfortably

because of our focus on ergonomics

The operating elements of the TruMark Station 3000 are ergonomically attached, and it is controlled via the tried-and-tested TruTops Mark software. An automatic door facilitates quick and comfortable loading and unloading. In addition, a motorized Z-axis supports component positioning and the achievement of the exact focus position.

03

Compact desktop application

with the TruMark one-box lasers and the TruMark 6030

Equipped with a TruMark one-box laser, the TruMark Station 3000 will even fit onto your desk thanks to its compact outer dimensions.

04

Perfectly equipped

for any application or batch size

The TruMark Station 3000 offers optimum compatibility with the TruMark Series marking lasers, and therefore offers the ideal solution for any application and small and medium batch sizes. An optional rotational axis further enhances the flexibility of the marking station. And if you wish to convert to series production, simply remove the side flaps and pass your conveyor belt through.



You can also use the TruMark Station 3000 as a desktop workspace or as a stand-alone solution – the supply unit and extractor are integrated into the substructure.

05

Mark safely

with a motorized laser protection door and laser safety class 1

Excellent safety in a compact design: the electrically operated and monitored laser protection door ensures the safety of your staff.



The laser protection door is electrically operated and monitored – perfect safety for your staff.



For further details on the TruMark Station 3000:
www.trumpf.com/s/trumark-station-3000



TruMark Station 5000

The intelligent all-rounder for those who like to make things easy.

01

Customized applications

with a wide range of options

04

Can be used anywhere

in the production line or as a single workstation



02

Work in safety

thanks to integrated extractor

03

Flexible integration

with the option of transferring workpieces lengthways

01

Customized applications

with a wide range of options

TruMark Station 5000 offers numerous options such as a rotary axis, collet chuck and various extraction systems. In this way, the system can be perfectly tailored to your application requirements.

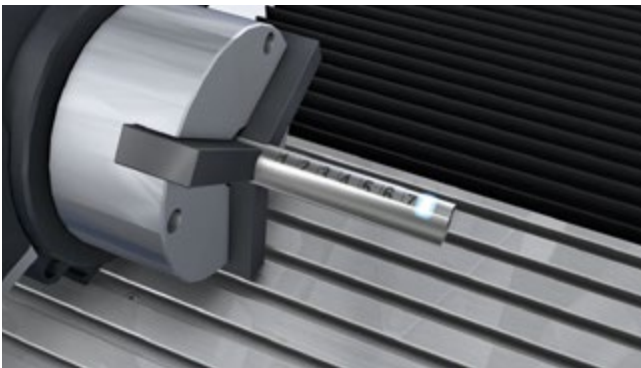

One possible option is to equip the TruMark Station 5000 with a rotary axis.

02

Work in safety

thanks to the integrated extractor

The smoke and particle emissions extractor is integrated in the TruMark Station 5000's housing and connected to the work area. The combination filter with activated carbon is monitored using a differential pressure controller, and the volume flow can be set.



The integrated extractor protects staff from smoke and particles.

03

Flexible integration

with the option of transferring workpieces lengthways

The TruMark Station 5000 makes it easy for you. You can easily integrate it into your flow line thanks to the housing's side openings for the flow through transfer of workpieces. You also have the option to expand the sealed work area on both sides.



Removable side flap for integration into your flow line.

04

Can be used anywhere

in the production line or as a single workstation

Benefit from the unbeatable combination of a larger work area and a compact design. The TruMark Station 5000 makes the perfect addition to your production line – or it can simply be set up as a single workstation. Do you prefer to sit or stand when working? You can do either thanks to the machine's intelligent, ergonomic design.



TRUMPF has conducted numerous applications trials to prepare the TruMark Station 5000 for flexible usage in industry.



Visit the website of our all-rounder, TruMark Station 5000: www.trumpf.com/s/trumark-station-5000



TruMark Station 7000

Robust and flexible.

01

Marking of large and heavy components

thanks to the use of a mineral cast plate

TruMark Station 7000 with lifting door



04

Batch production specialist

thanks to a large work area

TruMark Station 7000 with rotary table



02

Easy to operate

thanks to intuitive software

03

Perfect application results

thanks to a large selection of integrated beam sources

01

Marking of large and heavy components

thanks to the use of a mineral cast plate

The TruMark Station 7000 marking system offers plenty of space for your workpieces and devices with its large interior dimensions. It is possible to mark individual large or heavy components, or a large number of smaller parts alongside each other in one workpiece holder and process them automatically. The machine is designed to be extremely rigid, and contains a mineral cast plate as a central element. This facilitates precise markings, even for heavy and large components.



The large work area of the TruMark Station 7000 makes it possible for washing machine panels made of plastic to be easily and quickly marked with a UV marking laser.

02

Easy to operate

thanks to intuitive software

You can use TruTops Mark 3D marking software to quickly configure the laser process and marking content for your respective application. A further benefit of the software is its intuitive operation, which can also be used to perform complex manufacturing tasks.

You can optimally connect your system to your production environment with additional options. For example, you can easily use your TruTops Mark Module Interface to create process programs, read and write information from and to databases or external sources, automatically generate correct UDI codes, and integrate VisionLine image processing for position recognition and quality assurance. This leads to flexible, easy, and error-free manufacturing processes while increasing the traceability and productivity of your production.

03

Perfect application results

thanks to a large selection of integrated beam sources

A number of lasers with different power classes, wavelengths, and pulse durations are available for the TruMark Station 7000. Furthermore, additional options such as a rotary table, focusing lenses, camera systems and lighting provide additional flexibility. For example, rotationally symmetrical workpieces can be fully processed using swivel mechanisms and rotary axes, making many different applications possible.



Scalpels always have a UDI code in the same place.

04

Batch production specialist

thanks to a large work area

The TruMark Station 7000 can be easily integrated into efficient batch production. Large workpiece carriers for a variety of workpieces can be integrated in the machining room and processed automatically. Automatic loading and unloading of workpiece carriers and connection to a storage system provide an additional boost in productivity.

As a result of its large work area and wealth of options, this station is ideal for handling large lot sizes – especially the variation with the rotary table option. The components are brought to the machining area and processed using a rotary table system. The machine can already be reloaded with components during the machining process.



Further details about the TruMark Station 7000:
www.trumpf.com/s/trumark-station-7000



Everything under control with TruTops Mark

With TruTops Mark, mastering laser technology is easy. The marking software is based on Windows 10 and available in several languages. TruTops Mark combines marking software, a CAD editor, a management tool for laser parameters and interfaces, sequence programming, and a sophisticated diagnostic tool. This means you have all aspects of your laser operations under control with just this one piece of software. And if you do not want to deal with the nitty-gritty of laser marking, NAVIGATOR is there to help. This laser parameter assistant brings our application development expertise to your business.

Simple operation

CAD editor in TruTops Mark

A sophisticated 3D CAD editor enables a continuous design process from the workpiece to the marking. Workpieces can be drawn or imported as a CAD file (e.g. STP). Marking content can be easily created or imported as a DXF file and can even be processed effortlessly on freeform 3D workpieces.

Managing parameters and interfaces

The large number of interfaces allows you to import variable data into your marking program. TruTops Mark also offers you plenty of options with regard to integration into existing production machinery via the control unit.

Parameter library

You can easily copy parameters you have already used to new marking files. This is a fast and productive means of creating new marking files. It also helps ensure that your parts are consistently marked with the same quality, even with multiple machines.

Adjusting the focal position

The camera solution lets you automatically set the correct focal position. This is an advantage when marking components with varying processing heights.

Simple integration

Integrated workflow programming

Integrated workflow programming allows you to load marking files as well as integrate and edit variables. Workflows can also be created, including messages and prompts to the laser operator. Shortcuts, sample programs and practical features such as autocomplete and debug mode make it even simpler.

TruTops Mark Module Interface (TTM-MI)

TruTops Mark also offers standardized module interfaces to suit your industry and your particular needs. These interfaces can easily be integrated into any production process. This includes a base module, a scan module, a database module as well as a camera module and a special UDI module for medical technology. Even customer-specific modules are possible.



Simple diagnostics

Diagnostic tool

This tool visualizes and analyzes laser operating data and displays a complete list of monitoring notifications and live status information. This means that faults can be quickly identified and corrected.

Laser Power Monitor

The Laser Power Monitor is an internal module for measuring laser power. It is conveniently controlled using the software.

Laser Power Calibration

The Laser Power Calibration option allows the power of the marking laser to be calibrated. The power reserves mean your marking results will look the same as the first day, even years after.

Simple processes

3D deep engraving

The new deep engraving tool makes it quick and easy to create a 3D ablation in CAD. For example, you can create stamping tools, emboss lettering or logos deep into the workpiece, or even engrave 3D designs.

Spot welding

With TruTops Mark, you can easily create weld seams for joining thin metal films. In doing so, you retain full control over the properties and energy input of the individual spot welds.

Day-and-night design elements

Would you like to design complex patterns easily? TruTops Mark makes it possible. With the area tool, hundreds of individual points are transformed into marking content – with just a few clicks.



Mark in the third dimension with TruTops Mark 3D.
Experience more: www.trumpf.com/s/trutopsmark-3D



A complete overview

With **VisionLine image processing software**, TRUMPF is setting new standards when it comes to object recognition, distance measurement, user-friendliness, and process reliability – tailored to the high requirements in industries such as automobile manufacture, medical technology, and white goods.

01

Process reliability

from read-in to quality control

05

Prepared for any task

thanks to modular design and individual functions

02

Dazzling performance

thanks to modern lighting functionality

03

Easy to do by yourself

with an intuitive user interface and attribute library

04

High productivity

thanks to sensitive cameras with high resolution

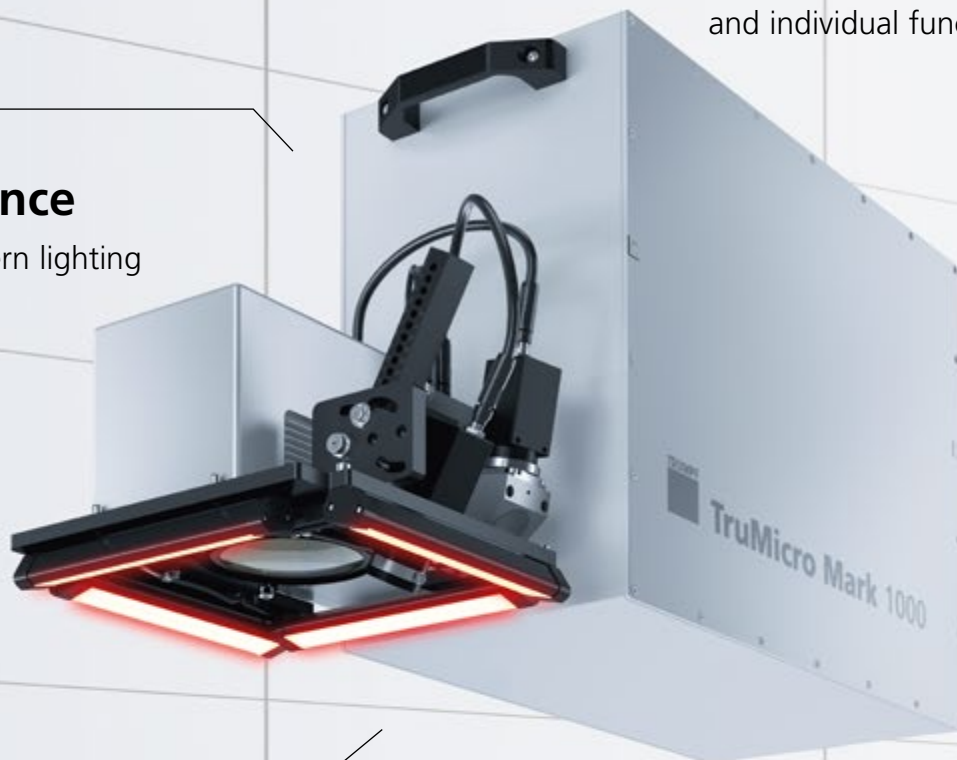

01

Process reliability

from read-in to quality control

- **VisionLine Detect:** Automated distance measurement and simple feature detection (e.g. circles, lines, and intersections)
- **VisionLine Model:** Learning and finding simple and complex geometries. Ensures that the marking process is always carried out at the correct position
- **VisionLine Code:** Automatic laser focus adjustment as well as reading and standard evaluation of bar codes and 2D codes
- **VisionLine Code and OCR:** Distance measurement to the workpiece and ability to detect and check fonts



TRUMPF VisionLine makes an optimum marking process possible.

02

Dazzling performance

thanks to modern lighting functionality

Thanks to state-of-the-art lighting functionality and homogeneous lighting conditions, you can create the best conditions for marking highly reflective surfaces and excellent contrast effects on a wide range of materials. The light diffuser is ideal for reducing the existing reflection.

03

Easy to do by yourself

with an intuitive user interface and attribute library

The intuitive user interface facilitates setup of the VisionLine image processing software for the operator. Whether setting up a new component, using predefined features, or defining parameters such as exposure times – the operator quickly and easily achieves the desired result.

04

High productivity

thanks to sensitive cameras with high resolution

With VisionLine, you can use sensitive cameras with high resolution, which contribute to efficient production thanks to short exposure times and quick image recording.

05

Prepared for any task

thanks to modular design and individual functions

VisionLine’s modular design can be precisely adapted to your task with its individual functions. You are optimally equipped for finding and checking the marking position and the distance to the workpiece. In addition, you always have an eye on the objects to be marked in the entire marking field and in the highest resolution.

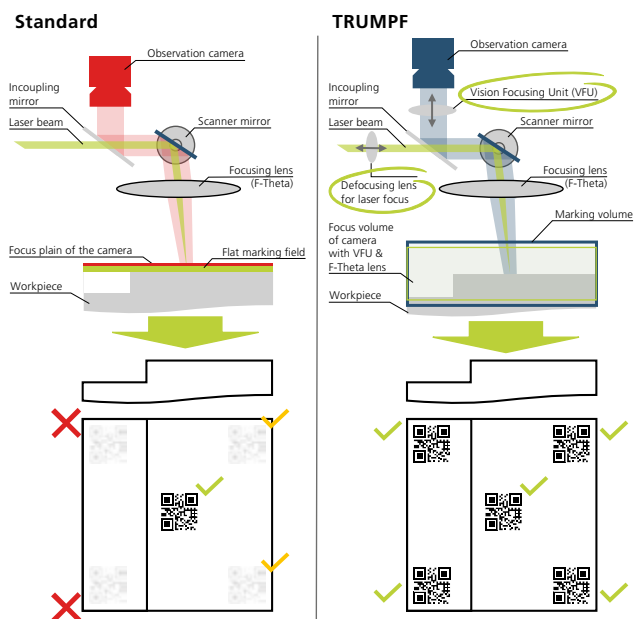

TRUMPF VisionLine facilitates the reading and evaluation of marking content on several processing levels.



Further information about image processing solutions:
[www.trumpf.com/s/
 image-processing-marking-applications](http://www.trumpf.com/s/image-processing-marking-applications)



All from one source

With **marking lasers and software solutions from TRUMPF for correct UDI marking**. TRUMPF has a broad range of marking lasers as well as customizable software solutions. You can use them to create correct UDI markings from your own databases and apply these markings to medical devices. Quality control and documentation functions are also available on request. With this complete package, you not only benefit from reliably high marking quality, but also from TRUMPF solutions for UDI-compliant marking and process reliability.



Equipped for the future

Ensure UDI compliance with our passivation-resistant laser marking solutions.



Process reliability

With our VisionLine Mark image processing, you can easily recognize, capture, and verify UDI content.



Automated

With a database connection, send sequenced UDI device identification (DI) and production identifiers (PIs) to the TruTops Mark software to automatically populate a recognized UDI bar code readable throughout the device's intended lifetime.



Efficient

Verify the laser-marked content and apply a customized grading for quality assurance to reduce time to clearance.



Certified

TRUMPF is a recognized GS1 Solution Partner. GS1 is one of four authorities that develops and issues UDI codes according to accredited standards to ensure the traceability of medical devices.

Customized UDI-compliant marking procedure using the TruTops Mark Interface Module:

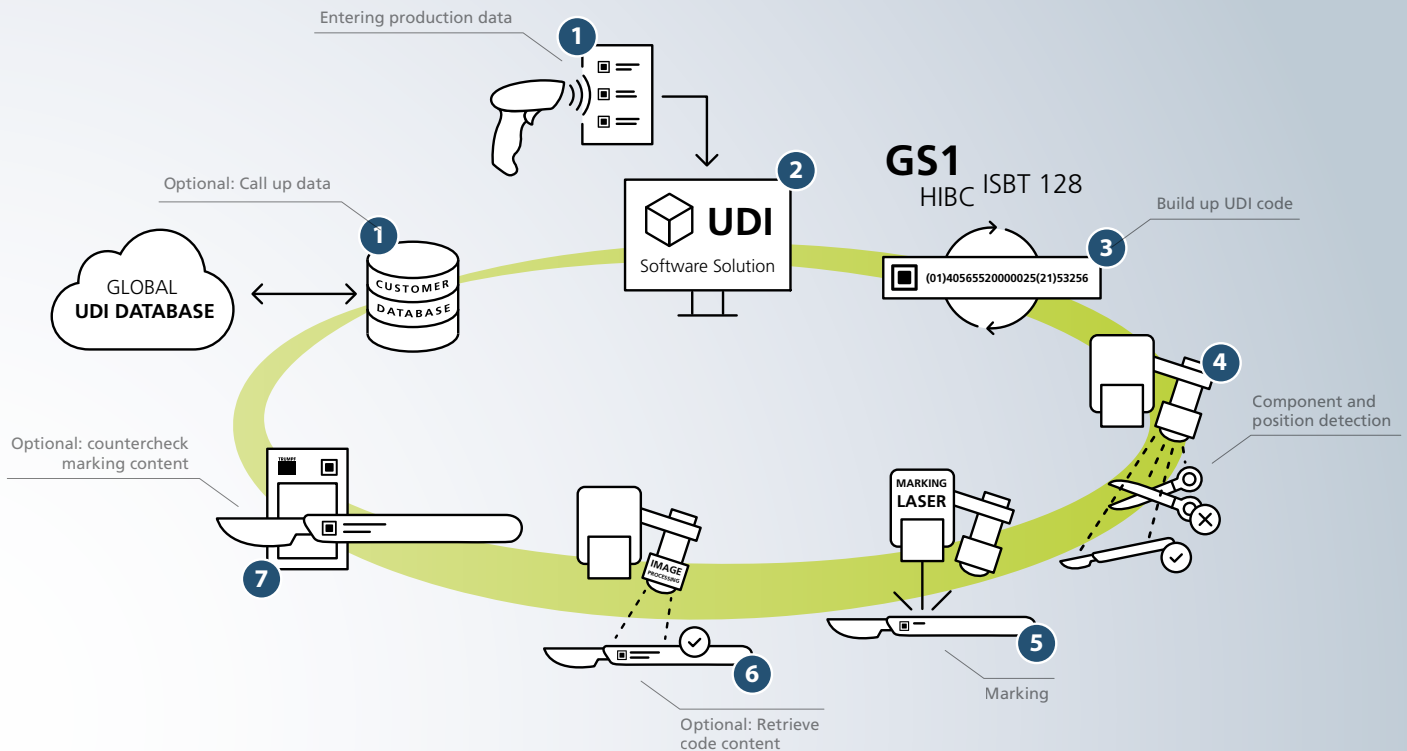

1 Access to database

The software is linked to databases. Reading information into the system via external hand scanners is also possible, for example.

2 Enter production data

Data is available from the database or read-out using a manual scanner.

3 Create UDI code

The UDI module creates a rule-compliant code from UDI-relevant data and individual extensions.

4 Component and position recognition

The image processing programs **VisionLine Detect** and **VisionLine Model** automatically detect the component and its exact location and position. The software forwards the information to the controller, which sets the marking in the precise position.

5 Marking laser function

The TRUMPF laser marks the workpiece with a durable, corrosion-resistant, and high-contrast marking that remains machine-readable and visible to the human eye even after numerous cleaning cycles.

6 Optional: Enter code content

Using TRUMPF process sensors, even the end quality control is very easy. The TRUMPF **VisionLine Code** image processing solution enables UDI-compliant codes to be detected, read out, and their quality evaluated using various procedures.

7 Optional: Compare marking data

Using the **VisionLine OCR** image processing programs (for character recognition) or **VisionLine Code** (for 1D/2D codes), the highlighted data can be compared with the database and stored for documentation purposes – if desired with additional information, e.g. about the content and quality assessment of the UDI code or about the machines involved in the process. This ensures proper documentation of the component and its markings even after many years.

Qualification support

How to reliably install and qualify laser systems. When designing and further developing our services, our main focus is on the especially comprehensive standards in medical technology and in the aerospace industry. As a result, our services are primarily based on the requirements of the following standards and institutions: ISO/ASTM 52941/52942, ISO 13485, ISO 9100, FDA, NADCAP, AMS 7003 and others. If you have questions regarding the details of our range of services or requirements based on your own company-specific standards that need to be taken into account, please do not hesitate to contact us – our experts would be glad to help.

We offer the following services:

- Installation Qualification (IQ)
- Operational Qualification (OQ)

Our expertise can also support you in additional qualification steps:

- Design Qualification (DQ)
- Performance Qualification (PQ)
- Maintenance Qualification (MQ)



More information on qualification support:
www.trumpf.com/s/qualification-support



Design Qualification (DQ)

We help you to select the optimum production technology for your application.

Content

- Consultation on the process and material processing
- Application tests for technology selection
- Customized solutions

Your benefits

- Foundation for successful equipment qualification
- Suitable economical and technical solution that meets your individual requirements

Installation Qualification (IQ)

Documented evidence that the device has been received as specified and is installed and configured for the intended application.

Content

- Scope of delivery check
- Machine installation check incl. hardware and software
- Completeness of documentation
- IQ report

Your benefits

- Time-efficient check of the scope of delivery and of the correct installation of the system by an expert

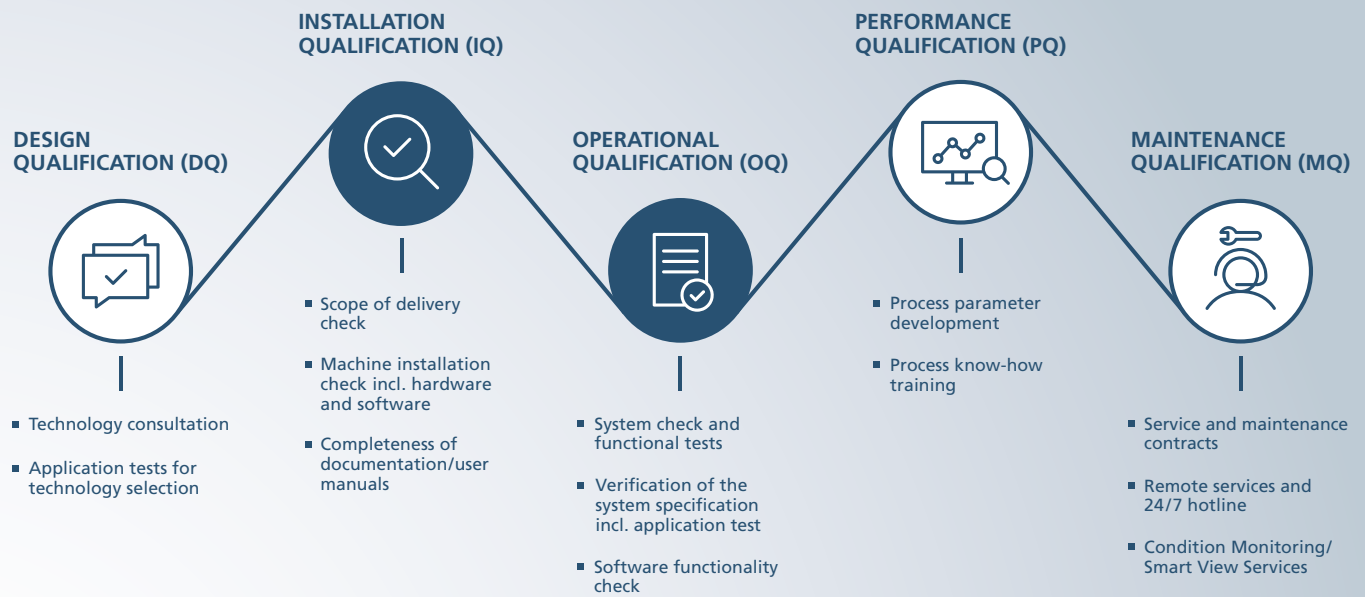

Operational Qualification (OQ)

Check of the correct basic functionalities of the system in the selected work environment. In this process, it is verified that the entire system works according to the specifications.

Content

- System check and functional tests
- Safety function check
- Verification of the system specifications
- Software functionality check
- Application tests
- Test record and OQ report

Your benefits

- Ensuring the specifications of the entire machine as defined in the DQ
- Time-efficient documentation of the specifications by an expert
- Ensuring proper operation of the machine for the start of PQ

Performance Qualification (PQ)

Observation of the system in the production process. Proof is provided that the defined performance parameters are consistently complied with and the system delivers reliable and repeatable results under real production conditions.

Content

- Performance of application tests to determine the process limits
- Imparting process know-how to employees

Your benefits

- Achievement of high quality and additional productivity through fine adjustment of the parameters
- Well-trained employees with an excellent understanding of the product and process ensure permanently stable and effective production processes

Maintenance Qualification (MQ)

Observation of the system in the production process. In doing so, we support the smooth series operation of your system with our services.

Content

- Training on system operation and maintenance
- Service and maintenance contracts
- Remote services and 24/7 hotline
- Support for application tests
- Equipment condition check
- Maintenance of machine qualification by checking and calibrating all process-relevant individual machine functions
- Consistent and detailed documentation of all measurement results

Your benefits

- High availability of the machines in production thanks to the offered services and TRUMPF's global presence
- Long-term use of the machines in the established customer process thanks to long-term availability of spare parts
- Well-trained employees ensure stable and effective production processes – because they perform maintenance themselves internally



Complementary services to maintain your certification

Initial qualification is only one part of the certification; it must be maintained by a Maintenance Qualification (MQ). With a wide range of service contracts available, TRUMPF provides the necessary support for fast reaction times and minimal machine downtime with transparent and controllable costs.

A comprehensive annual check-up of the entire system by our service experts – combined with the possibility of measuring the key influencing factors of the process yourself – facilitates continuously high production quality.

What happens in the event of an error correction, repair, or an update?

Certified production has specific requirements when it comes to the resumption of production after a malfunction. Based on a consultation and a detailed analysis of the situation, we jointly define which measures are to be taken to maintain the certified status and to reduce the effort required for requalification.

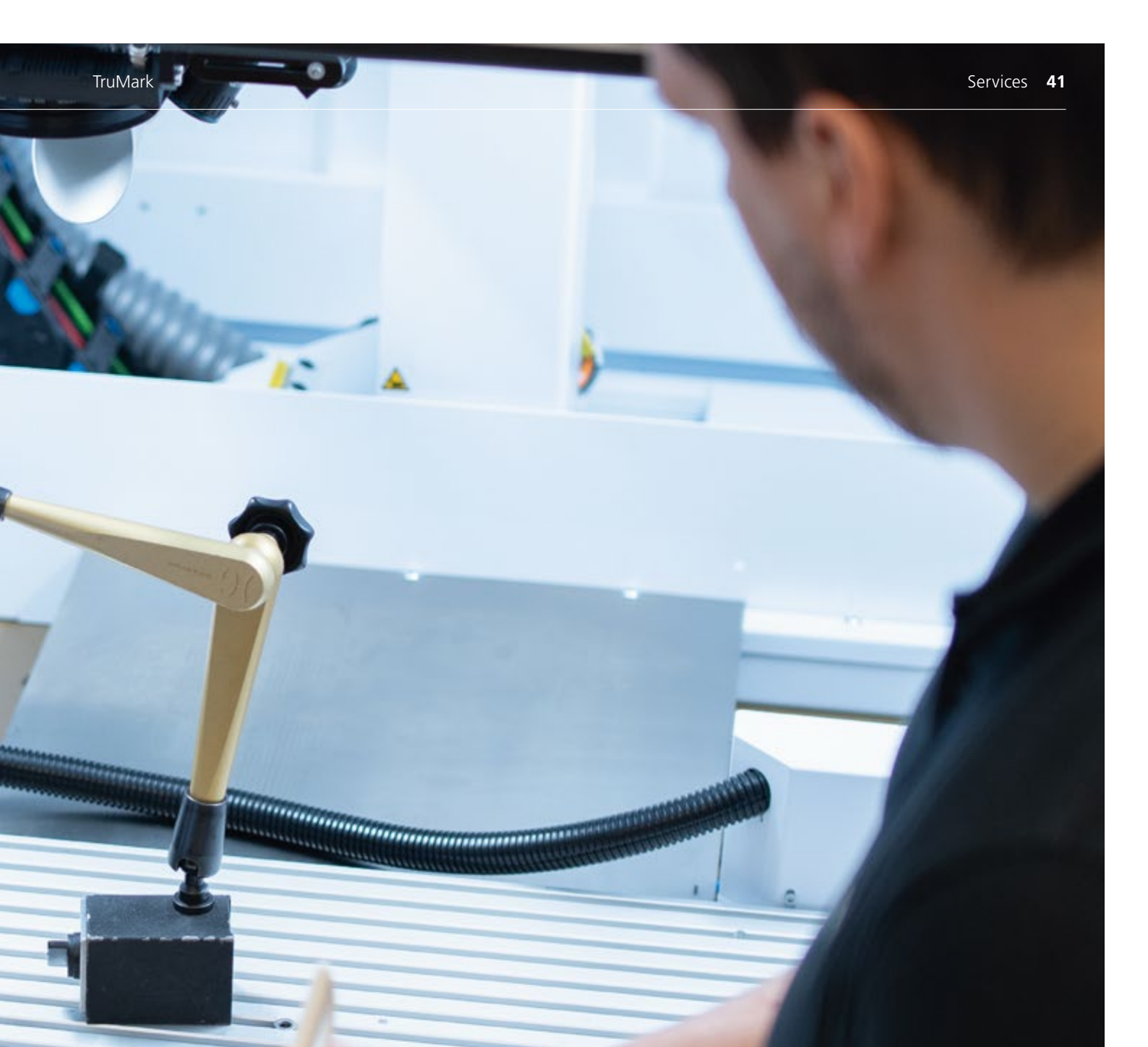

Our experts will be happy to inform you for which TruMark system we offer the service for qualification support.

The product-specific scope of services depends on the technical design of the machines and may therefore vary. Please do not hesitate to contact us if you have any questions or require further information.



Find out more about the customer story of toolcraft AG and its NADCAP certification: www.trumpf.com/s/oi4rcp



TruServices. Your Partner in Performance

To be successful in the future, you need the right services to keep you on track for the long term. Do you want to create the perfect manufacturing environment or make the best use of your TRUMPF equipment and tailor it to your evolving needs? Whatever the case, we're on hand to help you maximize your added value and lock those benefits in. TRUMPF is the right choice if you're looking for a reliable partner that can support you with a wide range of custom solutions and service packages, ensuring that your manufacturing business continues to be a resounding success.



EMPOWER

Looking to create the best conditions for successful manufacturing? We can give you the support you need.

SUPPORT

Are flexibility and machine availability top priorities in your ongoing manufacturing activities? We're on hand to help.

IMPROVE

Do you want to gradually shift your production processes towards maximum added value? We can achieve that together.

Technical Service



Do you want to get fast access to technical service? Or take proactive steps to maximize the availability of your TRUMPF system? Our global network of service teams is here to help! Whether your manufacturing business is based in Europe, America, or Asia, you can count on fast and professional support worldwide, covering everything from installation to maintenance and repairs. Simply call our Technical Service team and talk to a specialist to decide which is the most efficient way to handle your particular case – an on-site mission by one of our service engineers or troubleshooting with our Teleservice.

Process Optimization



Your processes are influenced by a whole host of different parameters, and adjusting those parameters can often unlock potential for optimization. Identifying that hidden potential is the key to making your production activities more efficient, and that's where we can help. With our help, you can uncover the hidden potential of your production process, for example by using our expertise to secure your competitive edge: TRUMPF specialists can offer you individual advice on your particular applications and can optimize your marking processes.

Monitoring & Analysis



Do you like the idea of constantly keeping tabs on the current status and performance of your marking laser? TRUMPF offers monitoring and analysis products that take transparency to the next level. Monitoring machine status and processes in real time shows whether the actions you take have the effects you want. Plus, you save time and money by preventing costly machine and plant downtime and identifying potential savings. An additional alarm function is also available for your marking laser, which updates you on process disruptions and their causes by e-mail or text message around the clock. Enabling you to react as quickly as possible.

Service agreements



Our service agreements offer a range of service packages to help make your manufacturing business run more smoothly. By bundling different services together, we can offer cheaper packages with less hassle and complexity, so you can simply choose the package that best suits your needs at a fixed price you can budget for. Continuous access to professional support maximizes machine availability over the long term, ensuring consistently high production quality and low running costs. Regular servicing by the manufacturer also increases your machines' service life.



You can learn more about our complete and comprehensive package of useful services here: www.trumpf.com/s/services

Technical data

TruMark Station 3000, 5000

Technical data			
		TruMark Station 3000	TruMark Station 5000
Available marking lasers		TruMark 1110, TruMark 5010, TruMark 6030	TruMark 3330, 5020, 5050, 6030
Dimensions (W x D x H)	mm	625 x 730 x 672/1092 ¹⁾	860 x 1312 x 2010/2310 ¹⁾
Weight (without laser, supply unit)	kg	82	480
Electrical connection (voltage)	V	120/230	
Electrical connection (frequency)	Hz	50/60	
Electrical connection (amperage)	A	16 at 230 V, 20 at 120 V	
Max. power consumption	W	1300	1800
Max. workpiece dimensions (W x H x D)	mm	450 x 350 x 200	384 x 375 x 500
Max. workpiece weight	kg	12	50/25 (mit X/Y-Achse)
Available axes		Z	X Y Z
Max. travel	mm	200	300 300 500
Max. traveling speed	m/min	3.75	6 6 3.75
Rotational axis	mm	65	65, 150
Door		Motorized	
Extractor		Integrated, external possible	
Laser safety class		1	

¹⁾Height of the machine with open lifting door.

Subject to alteration. Only specifications in our offer and order confirmation are binding.

TruMark Station 7000, 7000 with rotary table

Technical data			
		TruMark Station 7000	TruMark Station 7000 with rotary table
Available marking lasers		TruMark 3330, 5050, 6030, 7050 TruMicro Mark 1020, 2030	TruMark 3330, 5050, 6030
Dimensions (W × D × H)	mm	1150 × 1420 × 2000/2556 ^[1]	1150 × 1624 × 2000/2524 ^[1]
Weight (without laser, supply unit)	kg	1250	1400
Electrical connection (voltage)	V	120/230	
Electrical connection (frequency)	Hz	50/60	
Electrical connection (amperage)	A	16 at 230 V, 20 at 120 V	
Max. power consumption	W	2500	1800
Max. workpiece dimensions (W × H × D)	mm	960 × 375 × 500	Rotary plate Ø 770 mm
Max. workpiece weight	kg	100/50 (with Y-axis)	35 per side
Available axes		X Y Z	X Z
Max. travel	mm	650 350 500	650 500
Max. traveling speed	m/min	6 6 6 ^[2]	6 6
Rotational axis	mm	125	
Door		Motorized	
Extractor		Integrated, external possible	
Laser safety class		1	

^[1] Height of the machine with open lifting door.

^[2] 3,5 m/min for TruMicro Mark 2023.

Subject to alteration. Only specifications in our offer and order confirmation are binding.

You can find more information at www.trumpf.com

- Technical datasheets available to download
- Ability to clearly compare up to three products
- Displays perfectly on any end device

Technical data

One-box laser

Technical data			
		One-box laser	
		1110	5010
Beam quality (M ²)/intensity distribution		< 1.5/TEM ₀₀	< 1.6 / low-order mode
Average power at the workpiece	W	5	18.5
Wavelength	nm	1064	1062 ±3
Pulse duration		ns	
Pulse repetition frequency	kHz	15 – 100	1 – 200
Min. focal diameter	µm	50	40
Max. internal focus position control	mm	±7	24
Max. marking field size	mm ²	110 × 110	170 × 170
Standard marking field size	mm ²	110 × 110	
Electrical connection values			
Line voltage		24 V ± 10%	
Power consumption		20 A at 24 V	
Power	kW	max. 0.48	
Line frequency	Hz	–	–
Dimensions			
Processing unit dimensions (W × D × H)	mm	172 × 236 × 333	250 × 175 × 430
Supply unit dimensions (W × D × H)	mm	–	–
Installation			
Protection class	IP	54 (complete system)	
Permitted ambient temperature	°C	15–40	

Subject to alteration. Only specifications in our offer and order confirmation are binding.

TruMark Series 3000, 5000

Technical data					
		TruMark Series 3000		TruMark Series 5000	
		3230	3330	5020	5050
Beam quality (M ²)/intensity distribution		< 1.2/TEM ₀₀	< 1.5/TEM ₀₀	< 2.0 / low-order mode	< 1.6 / low-order mode
Average power at the workpiece	W	7	2.3	20	45
Wavelength	nm	532	355	1062 ±3	
Pulse duration		ns			
Pulse repetition frequency	kHz	1–100	1–120	cw, cwm, 1–1000	
Min. focal diameter	µm	15	16	41	28
Max. internal focus position control	mm	± 40	± 25	± 60	
Max. marking field size	mm ²	230 × 230	220 × 220	290 × 290	
Standard marking field size	mm ²	110 × 110	80 × 80	110 × 110	
Electrical connection values					
Line voltage		min. 100 V – 15%, max. 240 V + 10%, wide-range input			
Power consumption		2.6 A at 230 V, 6.0 A at 100 V		3.0 A at 230 V, 7.0 A at 100 V	
Power	kW	max. 0.6			
Line frequency	Hz	50/60			
Dimensions					
Processing unit dimensions (W × D × H)	mm	138 × 138 × 380	138 × 207 × 450	414 × 131 × 147	
Supply unit dimensions (W × D × H)	mm	445 × 465 × 420		445 × 550 × 420	
Installation					
Protection class	IP	54 (complete system)			
Permitted ambient temperature	°C	15–40			

Subject to alteration. Only specifications in our offer and order confirmation are binding.

You can find more information at www.trumpf.com

- Technical datasheets available to download
- Ability to clearly compare up to three products
- Displays perfectly on any end device

Technical data

TruMark 6030, 7050

Technical data			
		TruMark 6030	TruMark 7050
Beam quality (M ²)/intensity distribution		< 1.3/TEM ₀₀	≤ 1.6 (Z fiber) / ≤ 6 (M fiber)
Average power at the workpiece	W	25	170
Wavelength	nm	1030	1062 ± 3
Pulse duration		ns	
Pulse repetition frequency	kHz	40–200	max. 4000
Min. focal diameter	µm	50	40 (Z fiber) / 150 (M fiber)
Max. internal focus position control	mm	± 50	± 21
Max. marking field size	mm ²	330 × 330	285 × 285
Standard marking field size	mm ²	180 × 180	
Electrical connection values			
Line voltage		90 ~ 264 V, wide-range input	90 ~ 264 V ± 10%, wide-range input
Power consumption		8.5 A at 230 V, 15 A at 115 V	15 A at 115 V, 8.5 A at 230 V
Power	kW	max. 1.6	
Line frequency	Hz		50/60
Dimensions			
Processing unit dimensions (W × D × H)	mm	156 × 214 × 435	144 × 161 × 574
Supply unit dimensions (W × D × H)	mm	222 × 446 × 495	
Installation			
Protection class	IP	20 (supply unit, control computer), 54 (with supply cabinet), 64 (processing unit)	20 (supply unit, beam source controller module, control computer), 54 (processing unit)
Permitted ambient temperature	°C	15–40	

Subject to alteration. Only specifications in our offer and order confirmation are binding.

TruMicro Mark Series

Technical data		TruMicro Mark Series	
		1020	2030
Beam quality (M ²)/intensity distribution		≤ 1.3	
Average power at the workpiece	W	10	20
Wavelength	nm	1030	
Pulse duration		fs	ps / fs / flexible
Pulse repetition frequency	kHz	max. 2000	
Min. focal diameter	µm	46	29
Max. internal focus position control	mm	± 50	± 40
Max. marking field size	mm ²	330 × 330	180 × 180
Standard marking field size	mm ²	180 × 180	110 × 110
Electrical connection values			
Line voltage		115 ~ 230 V ± 10%, wide-range input	
Power consumption		15 A at 115 V, 8.5 A at 230 V	21 A at 115 V, 10 A at 230 V
Power	kW	max. 1.5	max. 1.5
Line frequency	Hz	50/60	
Dimensions			
Processing unit dimensions (W × D × H)	mm	100 × 106 × 134	835 × 375 × 180
Supply unit dimensions (W × D × H)	mm	200 × 349 × 442	600 × 1225 × 825
Installation			
Protection class	IP	20 (supply unit, control computer), 54 (processing unit)	20 (control computer, control plug-in unit, Ethernet switch), 21 (supply unit), 54 (processing unit)
Permitted ambient temperature	°C	15–40	15–35

Subject to alteration. Only specifications in our offer and order confirmation are binding.

You can find more information at www.trumpf.com

- Technical datasheets available to download
- Ability to clearly compare up to three products
- Displays perfectly on any end device

Passion is what drives us

Whether it's production and manufacturing technology, laser technology, or material processing – we develop highly innovative products and services for you which are tailored to your industry and which are absolutely proven and reliable. We put everything we've got into giving you a compelling, competitive edge: expertise, experience, and above all passion.



Check out our
YouTube channel:
[www.youtube.com/
@TRUMPFtube](http://www.youtube.com/@TRUMPFtube)



Solutions for your future

With a step-by-step introduction to your Smart Factory, you can take advantage of digital networking opportunities. We partner with you on the path to networked production, delivering pragmatic, economical solutions that make your processes both more transparent and flexible.

This will allow you to maximize your resources while ensuring your production is fit for the future. We support you every step of the way until your production runs perfectly for your needs.

Machines & systems

Laser cutting in 2D and 3D, punching, bending, laser welding and punch laser processing: With custom-fit machine tools, laser systems, software, and automation from TRUMPF, you can master flexible sheet metal and tube processing. Additive manufacturing solutions round off our portfolio – a portfolio that includes consulting, software, and services.



Lasers

Whether for cutting, welding, marking or processing surfaces, with lasers from TRUMPF you have the universal tool for your industrial applications. Choose the ideal system solution for you from the macro, micro and nano ranges. We will also support you with software solutions, application knowledge and consulting.



VCSEL solutions & photodiodes

Laser and photodiodes from TRUMPF Photonic Components come into their own in numerous applications: in the industrial and consumer markets and even in optical data communication. A VCSEL (Vertical Cavity Surface Emitting Laser) laser diode emits light perpendicular to the plane of the semiconductor chip. In the TruHeat VCSEL systems, millions of VCSELs generate infrared heat, which is used for laser heat treatment.

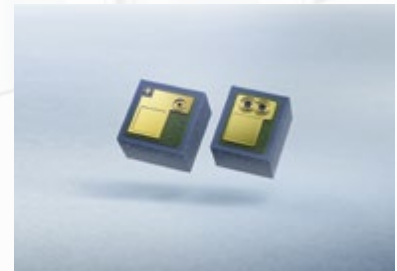

Power electronics

Nothing's hi-tech without a process power supply: With generators for plasma technology, industrial heating, battery inverter systems and microwave amplifiers, you get power at the frequency and performance you need. These technologies can be found in smartphones, for example, on glass facades, in PV systems or in microchips.



Power tools

Whether for cutting, connecting, and edge forming of sheet metal, professionals all over the world rely on the user-friendly electric and battery-powered tools from TRUMPF. On construction sites and in workshops, the quality products manufactured in Switzerland convince, gain and retain fans with their modern technology and perfect handling.



TRUMPF is certified to ISO 9001
(Find out more: www.trumpf.com/s/quality)

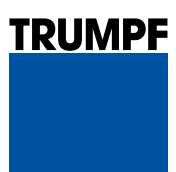

TRUMPF Laser- und Systemtechnik GmbH
www.trumpf.com